



Spec Master HPD6240 Series

6.0 Purity Two Stage Nickel Plated Brass Piston Differential Autochange Gas Control Panel



The Spec Master HPD6240 Series two stage differential autochange control panels are designed for primary pressure gas control of non-corrosive or toxic, high purity gases up to grade 6.0 purity (99.9999%), on gas distribution systems where constant delivery pressure is required.

- **HPD6241** Series | Two Stage Twin Cylinder Piston Differential Autochange Gas Control Panel, FKM Seal
- **HPD6242** Series | Two Stage Twin Cylinder Piston Differential Autochange Gas Control Panel, EPDM Seal

★ FEATURES

- High pressure isolation valves
- High pressure purge facility
- Two stage pressure regulation
- Process line isolation valve
- Encapsulated valve design
- Twin cylinder configuration

📁 MATERIAL

■ Body	Nickel Plated Brass Barstock
■ Bonnet	Nickel Plated Brass Barstock
■ Piston	Brass
■ Seal Option	FKM / EPDM
■ Valve Seat	PCTFE
■ Filter	10 Micron 316L Stainless Steel

👍 SPECIFICATION

■ Maximum Inlet Pressure	60 bar (870 PSI) 300 bar (4350 PSI) *
■ Delivery Pressure Range	20 bar (290 PSI) 50 bar (725 PSI)
■ Gauges	50mm (2") Diameter
■ Ports	1/4" NPT Female
■ Temperature Range	-20° C to +60° C (-4° F to +140° F)
■ Helium Leak Integrity	1x10 ⁻⁹ mbar l/s
■ Weight	8.00 kg (17.64 lbs) ****

* Subject to cylinder connection – **** Subject to final configuration

✓ FLOW PERFORMANCE

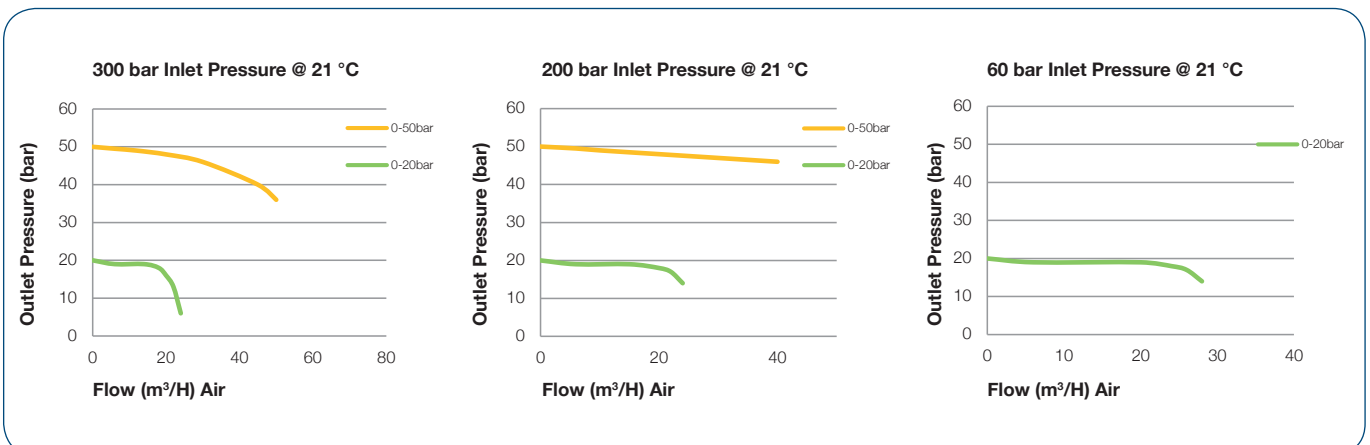

DRAWINGS

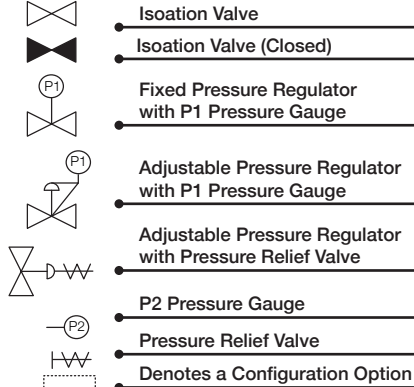
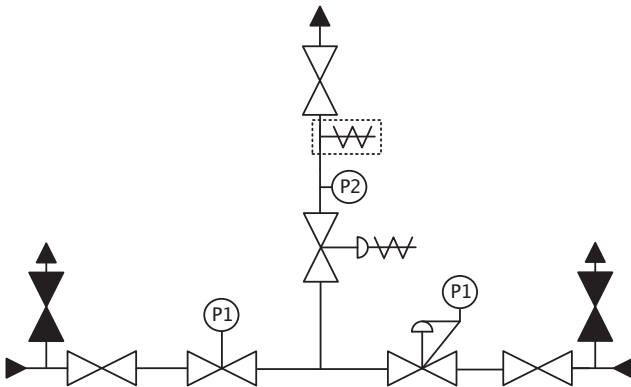
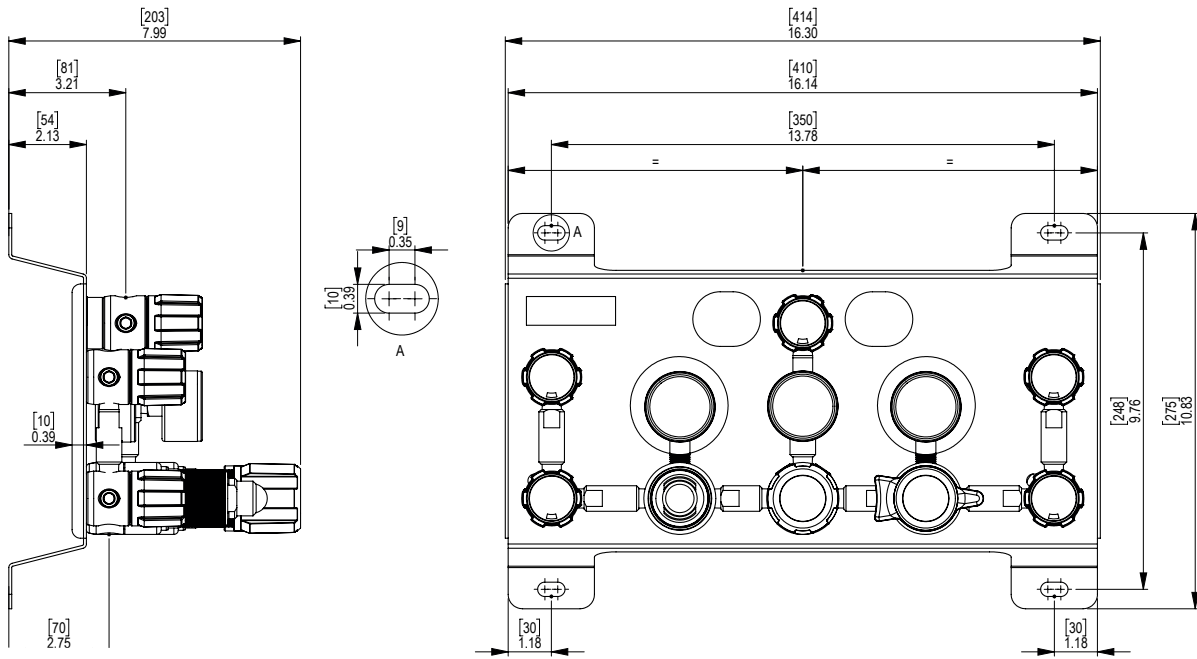

1 2 3 MODEL NO. SELECTOR GUIDE

Example for a Model No. for HPD6240 Series

HPD6241- 02- 07- 00- 00- 000- 00- A

Product Type	Inlet Pressure Bar [PSI]	Outlet Pressure Bar [PSI]	Inlet Pressure Gauge	Outlet Pressure Gauge	Inlet/Cylinder Connection	Outlet Connection	Options
HPD6241	02 60 [870]	07 0 to 20 [300]	00 No Gauge Fitted	00 No Gauge Fitted	000 1/4 NPT Female	00 1/4 NPT Female	A No Options Selected
HPD6242	04 300 [4350]	10 0 to 50 [725]	01 bar/PSI	01 bar/PSI	001 1/8 Stainless Steel Compression	01 1/8 Stainless Steel Compression	F Bonnet Vent Capture Kit
			02 bar/PSI Contact Gauge		002 1/4 Stainless Steel Compression	02 1/4 Stainless Steel Compression	G Helium Test Certificate
					003 6mm Stainless Steel Compression	03 6mm Stainless Steel Compression	K Certificate of Conformity (CoC)
					004 1/4 NPT Male	04 1/4 NPT Male	M CO2 Burst Disc
					007 G3/8 BSP R/H Brass Male	07 G3/8 BSP R/H, Brass, Male	P Calibration/ Pressure Test Certificate
					008 G3/8 BSP L/H Brass Male	08 G3/8 BSP L/H, Brass, Male	R Fitted Pipeline Pressure Relief Valve
							X Special Instruction